

Fitting The Record / Playback Module (RPM) to Megane Models

Version 2

**Applicable to: Megane and Megane Scenic models 1995-99 approx.
With Infra-red & transponder keys**

**Note: The process described here is only effective if you are fitting a pre-programmed RPM bypass unit.
Read the instructions carefully especially the notes at the end....**

General

The Record / Playback Module (RPM) needs to be fitted to the back of the Interior Fuse Box / Body Control Unit. This is mounted on the right hand side of the steering column, and is held down by one fixing screw (centre one) and two pivot pins: It is usually necessary to disconnect the 2 plugs on the underside of the Body control unit nearest the drivers kick panel first. Remove centre screw and push the BCM unit backwards and downwards. Check that the harness does not get caught on the threads of the bolt that goes through steering column



All the connections shown need to be made to connectors on the top (black) face of the unit.

Connections should be made using soldered joints.

Connection points are as follows:

1. Ignition: Splice red wire of RPM into wire from Pin B5 on Blue 14 way connector.

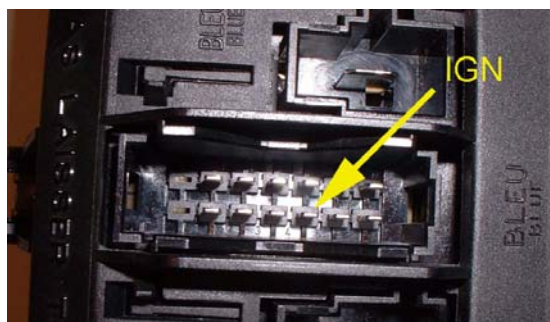

Wire colour is usually yellow, but see the note at the end of this document!

2. Ground: Splice black wire of RPM into wire from Pin A7 on 16 way white connector.

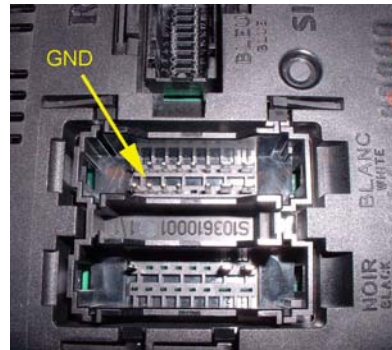
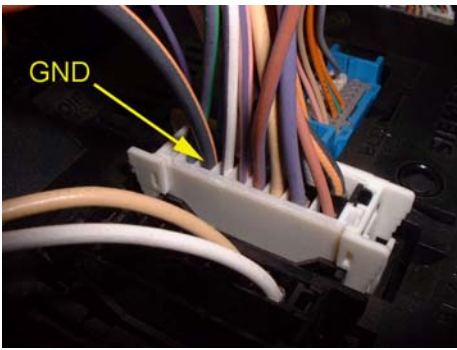

Wire colour is usually black / orange, but see the note at the end of this document!

3. Data to Engine ECU:- Splice the yellow wire from the RPM Module into the wire from Pin 5 on **20 Way Black connector (actually a white & grey plug) Usually a **GREEN** wire

NOTE: ARROW IS POINTING AT **GREEN** DATA WIRE

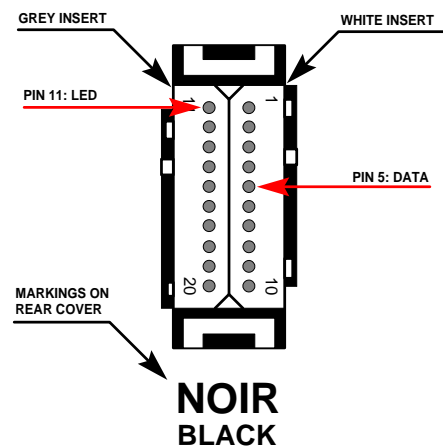
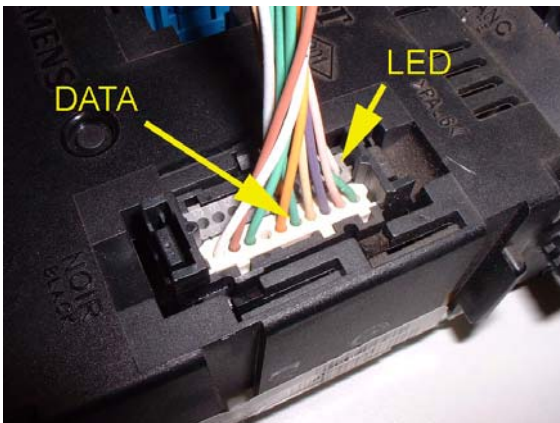

Connector shown diagrammatically

Wire colours are usually **green** for data, and white for the security LED, but once again, see the note at the end of this document!

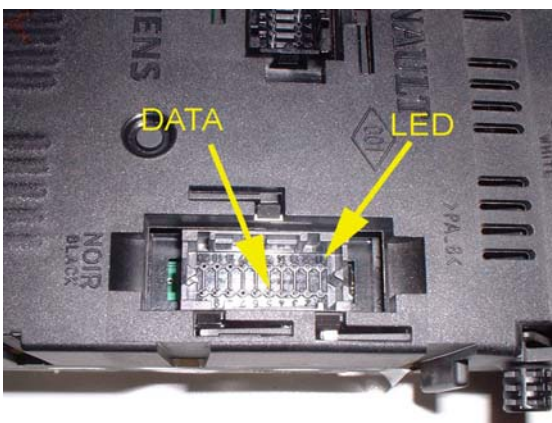

4. Now cut DATA WIRE (usually **GREEN**) FROM pin 5 on **20 way black connector so that only the RPM unit **YELLOW** wire is connected to DATA wire to engine ECU. (See Schematic on next page).
Do not cut it 'flush' with 20 way connector

Cut wire from Pin 5 on 20 way black connector so that only the Yellow wire from the RPM unit is connected to data wire to engine ECU

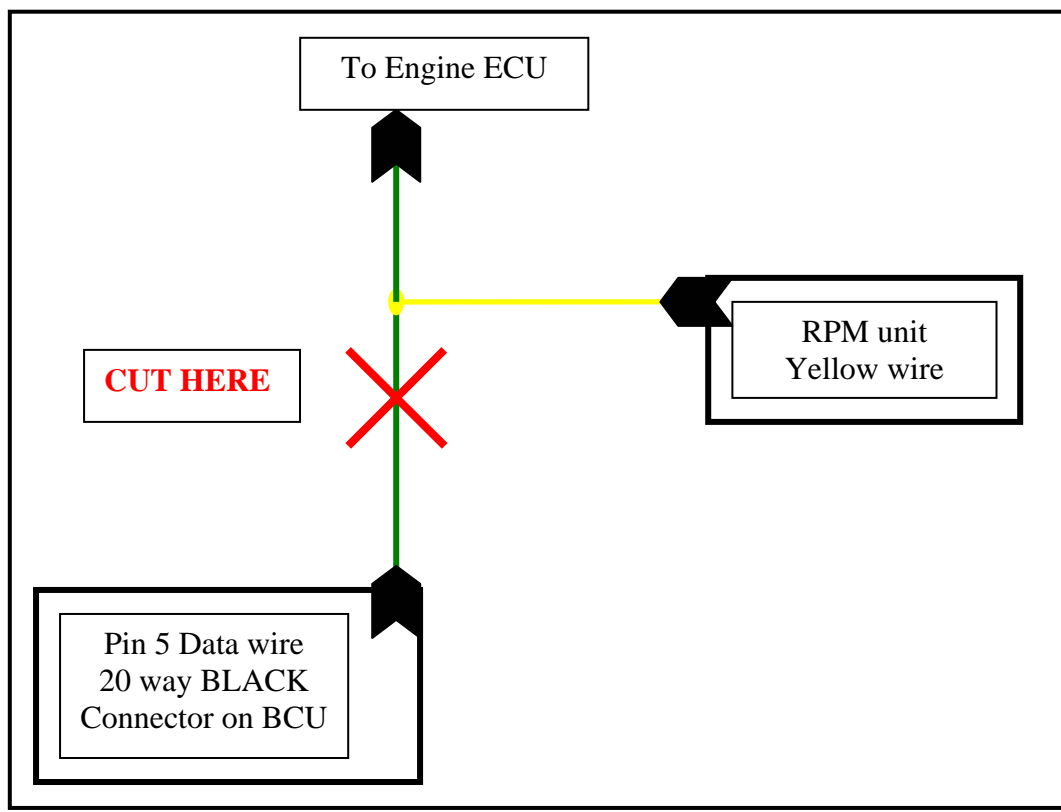

Turn ignition ON engine ECU is now receiving data directly from the Record / Playback Module. Both the green and yellow LEDs should blink to show data is being sent. You can now start the vehicle

Screw the lid onto the Record / Playback Module and reassemble

=====

Note:-

You may also want to cut the wire to the red security LED, to stop it flashing and causing a distraction whilst driving. This is connected to Pin 11 of the same 20 way connector as the data wire and in this example is white

Note:-

The wire colours on the Renault wiring harness in the photos are for guidance only. Renault never specify wire colours, which means they're likely to change.

****Although the 20 way plug is actually white & grey in colour Renault denote it as black on Body control module**